

A LOW COST 2V TO 5V STEP UP CONVERTER

by G. AUGUSTONI

INTRODUCTION

The TS3V555 is the CMOS 3 Volt version of the famous versatile 555 timer which has the ability to work with voltage as low as 2V. This application note shows how to use this feature to build a micropower low cost step-up converter from 2V up to 5V.

The TS3V555 is used in a schematic that multiplies the supply voltage by a constant ratio fixed by an external resistor bridge. The Figure 1 circuit supply current is 100µA not loaded and is able to deliver 10mA with 50% efficiency.

Applications include power conversion with input voltage from 2V to 16V and output voltage only limited by external NPN voltage rating, 5V to 12V

conversion for flash programming, boost voltage for high side NMOS driving, ...

DESCRIPTION

TS3V555 has two threshold voltages determined by an internal accurate resistor bridge, Trigger (2) and Threshold (6).

The Trigger input is used for output voltage regulation, the threshold level is 0.7V (1/3 of Vcc). Output voltage is compared via R1/R2 resistor bridge to this level during Output (3) low cycle, switching it to high when voltage drop below Trigger threshold level. The output voltage is $V_{out} = (1+R2/R1) \times V_{cc}/3$.

The Threshold input is triggered at 1.3V (2/3 of Vcc), on the saturation voltage of the NPN, during the inductor charge cycle. As 1.3V is a high satu-

Figure 1 : Electrical Schematic

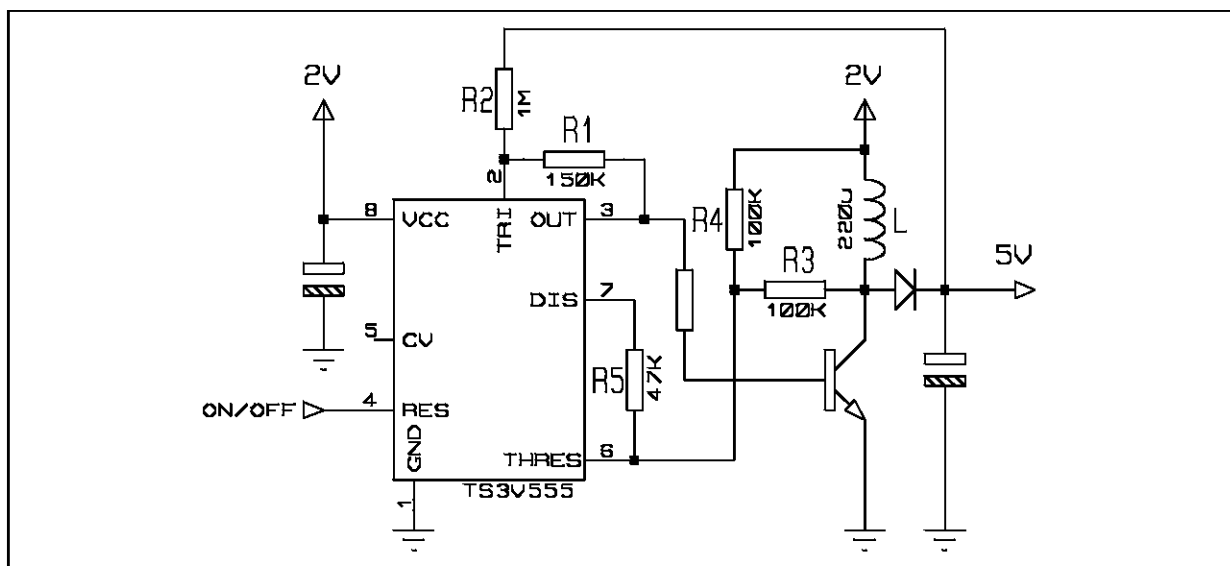

APPLICATION NOTE

ration value, Threshold voltage is decreased via a resistor bridge R3/R4 to 0.66V.

$$V_{th} = (2R_4 - R_3) / (3R_4) \times V_{cc}$$

To avoid any undesired triggering at the beginning of the inductor charge cycle, during NPN switching time (collector voltage is at Vcc), it is necessary to connect a resistor to Discharge pin(7) to decrease the Threshold input voltage below 2/3 of Vcc.

SPECIAL PRECAUTIONS

Accuracy of output voltage depend on accuracy of R1/R2 and internal (2% typ) bridge, internal comparator offset (10mV typ) and Output(3) Ron. Therefore, high resistor values must be used to limit influence of Ron dispersion. Trigger input current is negligible in the pA range.

Any capacitance on Trigger input will increase re-start time, decreasing maximum current capability of the circuit, but will improve frequency stability.

Figure 2 : OUT (1) and NPN Collector (2)

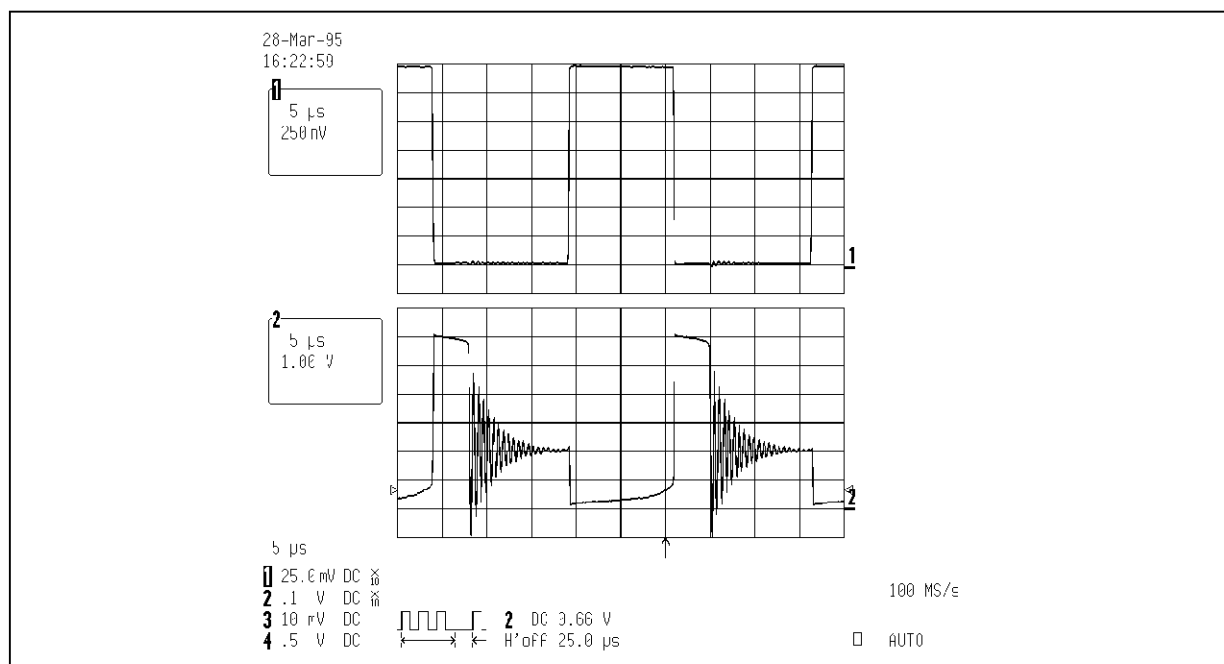

Information furnished is believed to be accurate and reliable. However, SGS-THOMSON Microelectronics assumes no responsibility for the consequences of use of such information nor for any infringement of patents or other rights of third parties which may result from its use. No licence is granted by implication or otherwise under any patent or patent rights of SGS-THOMSON Microelectronics. Specifications mentioned in this publication are subject to change without notice. This publication supersedes and replaces all information previously supplied. SGS-THOMSON Microelectronics products are not authorized for use as critical components in life support devices or systems without express written approval of SGS-THOMSON Microelectronics.

© 1996 SGS-THOMSON Microelectronics - All Rights Reserved

SGS-THOMSON Microelectronics GROUP OF COMPANIES

Australia - Brazil - France - Germany - Hong Kong - Italy - Japan - Korea - Malaysia - Malta - Morocco - The Netherlands
Singapore - Spain - Sweden - Switzerland - Taiwan - Thailand - United Kingdom - U.S.A.

ORDER CODE: